

CARDS 4 GAME

CREATIVITY AND CUSTOMIZATION

FILE PREPARATION MANUAL FOR PRODUCTION AT CARDS 4 GAME



1. INDEX
 - 1.1 FILE PREPARATION
 - 1.1.1 Accepted files
 - 1.1.2 Color management
 - 1.1.3 Product design
 - 1.1.4 Sending files to CARDS4GAME
 - 1.1.5 Sending files for customer verification and acceptance
 - 1.1.6 Graphic print distinction
 - 1.1.7 Card design
 - 1.1.8 Card areas, format and types



1.1 FILE PREPARATION

1.1.1 Accepted files

• PDF files

- File names cannot include special characters (à, á, †, *, <, +, etc.).
- The design must be presented at a 1:1 scale.
- All fonts used in the document must be embedded or converted to curves.
It is not advisable to replace fonts with a bitmap, as this may result in lower print quality.
- Page dimensions must be identical for all pages of the document.
- Files must be developed according to the CMYK, Pantone or CMYK + Pantone color schemes.
- Bitmap graphics must have a resolution between 300 and 350 dpi.
- Cut lines must be the only markers used when exporting files, their net offset must be min. 3 mm.
- Additional elements, such as: UV varnishes, presses, dies, etc., must be defined as 100% additional color (spot), must have overprint set and must be vector objects.
- All elements must be prepared on die grids provided by CARDS4GAME.
- All 100%K elements will be automatically overprinted (fonts, curves). White overprints will be ignored.
- The minimum line width for overprints must be 0.2 pt.
- It is unacceptable to include scans showing a screen from previous prints in the files.
- Each page of the PDF file must include a properly defined Trimbox and Bleedbox.
- The design must be centered in relation to the Trimbox and Bleedbox.
- Due to the technology, printing smooth gradients and uniformly colored backgrounds on substrates with uneven surfaces (e.g. canvas structure) may result in the emergence of small white spots in the depressions of the raw material.

1.1.2 Gestion des couleurs

- **Profil ICC:** Il est recommandé d'utiliser le profil ISO Coated v2 300 % (ECI) pour tous Conversions RVB-CMJN (www.eci.org).
- **Limite totale d'encre:** la limite maximale d'encre est de 300 %.
- **Gain noir:** pour obtenir une couleur noire profonde, il est recommandé d'utiliser le valeurs suivantes : C50% M40% Y30% K100%.
- Les petits graphiques et textes noirs doivent être définis à 100 % K et avoir une surimpression activé. Il est préférable de remplacer les éléments gris sur un fond coloré par une triade de gris. Les lignes fines inférieures à 0,75 pt doivent être définies comme une seule couleur. Cela permet d'éviter les inexactitudes liées à la correspondance dans le processus d'impression compenser. Les éléments imprimés sur des fonds de peinture de finition (par exemple métalliques) doivent avoir surimpression désactivée, c'est-à-dire qu'elles doivent être sélectionnées en arrière-plan.
Nous utilisons le piégeage pour ces types d'éléments. Ceci ne s'applique pas aux

éléments bitmaps, où le piégeage est effectué par le client. Un piège doit avoir une épaisseur d'environ 0,07 mm, surimpression activée et doit être un agrandissement de l'élément imprimé en arrière-plan.

1.1.2 Color Management

- **ICC Profile:** It is recommended to use the ISO Coated v2 300% (ECI) profile for all RGB-CMYK conversions (www.eci.org).
- **Total Ink Limit:** The maximum ink limit is 300%.
- **Black Gain:** To obtain a deep black color, it is recommended to use the following values: C50% M40% Y30% K100%.
- Small black graphic elements and texts should be defined as 100%K and have overprint enabled. Gray elements on a colored background are best replaced with a triad of grays. Thin lines under 0.75 pt should be defined as a single color. This helps to avoid inaccuracies related to matching in the printing process offset. Elements printed on topcoat backgrounds (e.g. metallic) must have overprint disabled, i.e. they must be selected in the background. We use trapping for these types of elements. This does not apply to bitmap elements, where trapping is done by the customer. A trap must have a thickness of about 0.07 mm, overprint enabled and must be an enlargement of the element printed on the background.

1.1.3 Product Design

- The principles of application of barcodes, their scale and acceptable color schemes are strictly in accordance with the standards available on the websites concerning the EAN barcode specifications. Barcodes and QR codes cannot be transformed into bitmaps and developed in CMYK, as there is a risk of misreading the code. It is also necessary to remember the protective area around the code: the code must be placed on a white field, not directly on the graphics.
- The use of product designations is determined by commercial law (Directive 2009/48/EC), symbols are not subject to change or the scope of changes is strictly determined.
- Small symbols and logos must be positioned as vector objects. Do not convert them into bitmaps



WARNING

CARDS4GAME does not verify the correct position or legal compliance of the above and similar characters.

1.1.4 Sending files to CARDS4GAME

PDF files can be sent electronically (FTP, email, "cloud" link, etc.) and in the form of physical media (CD, DVD, pendrive). Before sending the files, it is necessary to:

- Conduct a preliminary inspection of the file (Preflight – Adobe Acrobat PRO);
- Check the color separation of the file (Output preview – Adobe Acrobat PRO);
- Check overprints;
- Check if the bleeds of all the elements have been generated correctly;
- Check the central position of the design with respect to the Trimbox;
- Check the content, any display errors, printing errors, dangling modifiers, correct orientation of the front and back faces

1.1.5 Sending files for verification and customer acceptance

PDF files are sent electronically (FTP, e-mail, link to the "cloud", etc.).

Files sent for verification must always be viewed with the overprint preview enabled (Adobe Acrobat / Reader – Ctrl + K -> Page View -> Overprint Preview -> Always).

It is necessary to check the color scheme (CMYK, Pantone color separations), format of parts, content (texts and other objects), correct display of overprints (especially 100%K black and white).

CARDS4GAME verifies customer files on many levels and undertakes to notify the customer of any errors, but the company will not recognize complaints regarding products where the defects arise from incorrect preparation of the files for production.

CARDS4GAME is not responsible for changes in the graphics resulting from incompetent use of the overprint.

CARDS4GAME fixes minor errors in files in exceptional cases. All corrections in files are made under the sole responsibility of the customer.

1.1.6 Graphic Print Distinction

The distinction between "bleed" and "loose ground" refers to printing and graphic design techniques used in the production of playing cards and other printed materials.

1. Bleed

"Bleed" refers to a portion of the graphic that extends beyond the final edge of the printed product. This is important because during the cutting process, there may be small variations in the position of the cut.

By extending the image or color to and beyond the edge, you avoid the risk of leaving white spaces or unwanted edges on the finished product.

Simple explanation: Imagine you have a sheet of paper and you want to print an image that covers the entire sheet. If you cut the sheet, you may not be perfectly precise and you may end up with a white edge. Bleed is as if you have stretched the image a little beyond the edge of the paper, so that even if you do not cut perfectly, the image will still cover the edge.

2. Full bleed

Full bleed is a term that indicates that the image or color covers the entire surface of the paper, without any white edges. In practice, full bleed is the final result of bleed graphics, where the image is printed all the way to the edges, giving a professional and complete look.

Simple explanation: If we take the previous example, full bleed is the final result where the image is printed all the way to the edges of the paper, without any white space.

So, when you look at the playing card, you don't see any white edges around the image; everything is covered and it looks much nicer.

Summary

1. Full bleed: Part of the image extends beyond the edge of the product to ensure that there are no white edges after cutting.
2. Full bleed: Final result where the image covers the entire surface of the paper without any white edges

1.1.7 Card Design

PDF files for card production should be prepared in accordance with the above guidelines. Additionally, files should be divided into Front Sides, Back Sides, and decks, provided that the design includes more than one deck. The file naming scheme should be as follows:

- Front Side Deck 1 name.pdf
- Back Side Deck 1 name.pdf
- Front Side Deck 2 name.pdf
- Back Side Deck 2 name.pdf

The number and order of pages in each file should match the number and order of cards in the ordered deck. If a card is to appear repeatedly in the deck, it should be used in the file as many times as there are quantities of that card in the deck.

An exception is when a single card is to be repeated in the entire deck (back-common).

- 55-card deck:
 - Front side name.pdf (55 pages)
 - Back side name.pdf (55 pages)
- Two decks, 55 cards each, with a common back:
 - Front side Deck 1 name.pdf (55 pages)
 - Front side Deck 2 name.pdf (55 pages)
 - Back side Deck 1 and 2 name.pdf (1 page)

1.1.8 Paper Areas, Formats and Types

When designing papers, three basic graphic areas must be taken into account: graphic area, safety margin and "blood graphics" area.

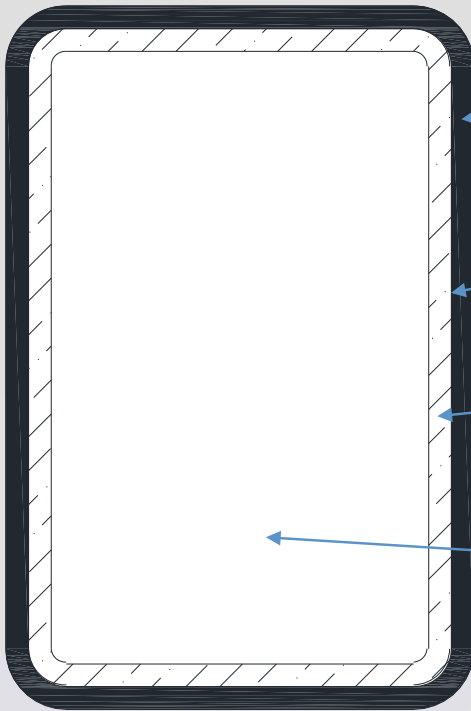

"Blood graphics" area: In the case of drawing without blood graphics, it is possible to omit the area or leave it blank. In the case of blood graphics, it is necessary to increase the safety margin by at least 3 mm on each side.

NET format: Size of the paper after production.

Safety area: Must separate the graphic elements from the net format by at least 3 mm.

Graphic area: It is necessary to place all the graphic elements in it. (net format minus the safety area)

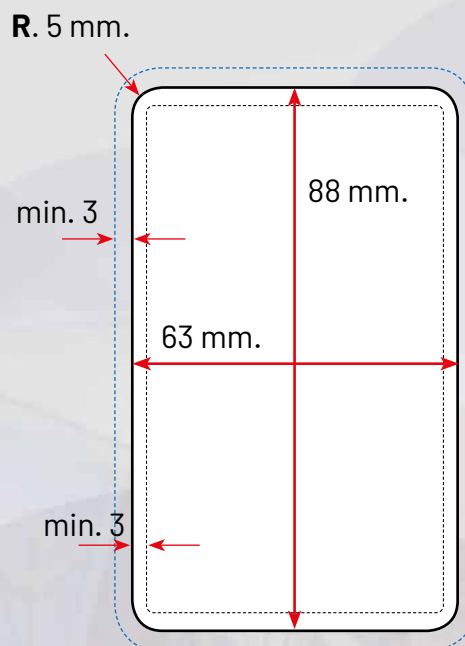

FILE PREPARATION MANUAL

In terms of production process, cards can be divided into three basic methods to prepare the design graphics. Except for ornamented cards, all other cards must have a border/ margin of the same color for the front or back sides. The border of the front side may differ from that of the back side. The cutting tolerance of the paper is ± 1 mm.

- Cards without blood graphics (white border or borderless);
- Cards with blood graphics (border or borderless);
- Cards with blood graphics (ornamented cards, with full graphics).

**Paper without
blood graphics
white border**



**Paper without
blood graphics
without border**



**Paper with
blood graphics
with border**

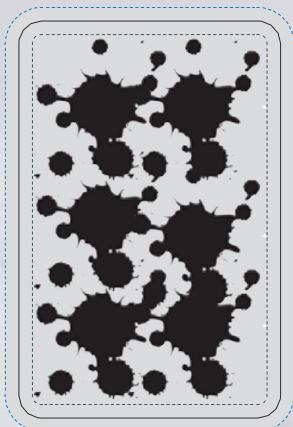

**Paper with
blood graphics
without border**

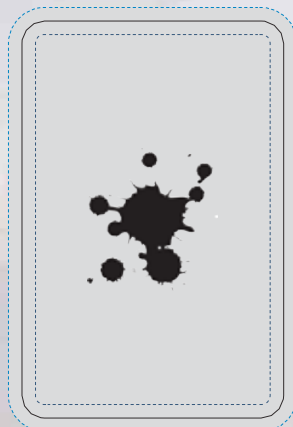

**Paper with
blood graphics
with full graphics**

